

Specifications

Chuck Model	Spindle Nose	Collet Model	Accuracy Max Radial Runout	Collet Capacity	Collet Clamp Range	Chuck Stroke Linear	Max Draw Tube Force	Max Clamping Force	Max Speed	Chuck Weight
CB65-NX/A8	A2-8	65BZI	.0004" 0.010mm	2.625" 66mm	+/- .020" 0.5mm	.160" 4mm	10,116 lbs 45 kN	23,605 lbs 105 kN	6,000 rpm	34.2 lbs 15.5 kg

Dimensions

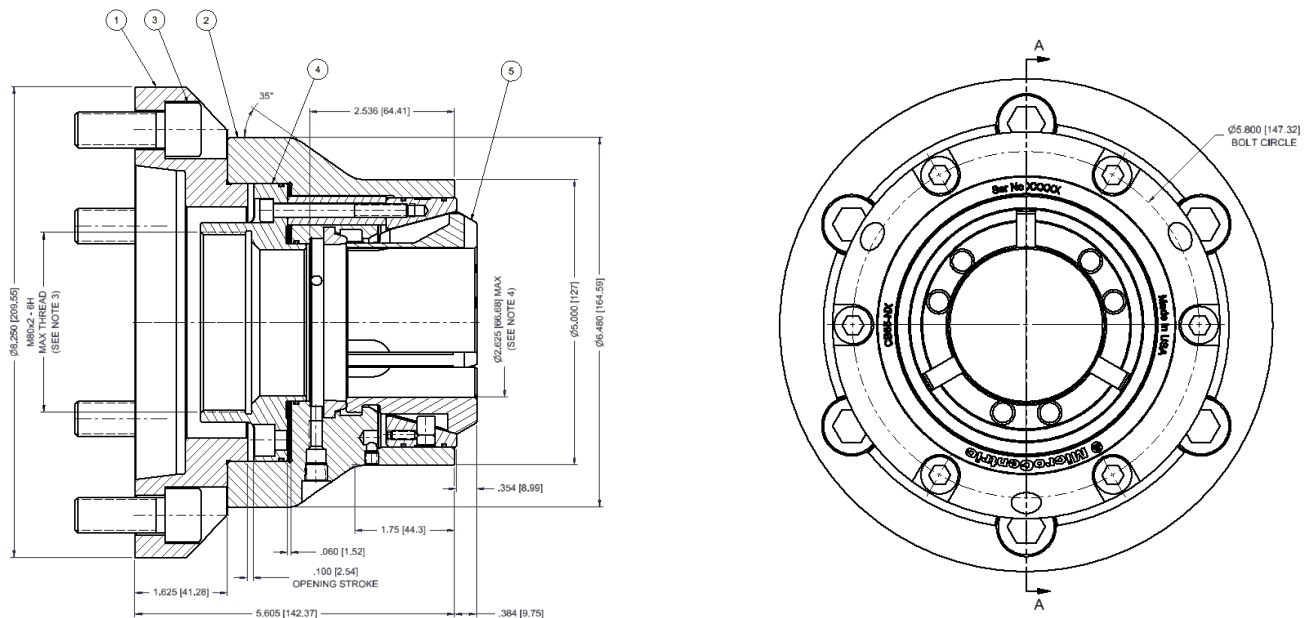

ITEM	QTY	PART NUMBER	DESCRIPTION
1	1	16 065 207	ADAPTER
2	1	16 065 537	FITTED BODY AND SLEEVE
3	6	83 196 M040	M16 x 40 SHCS
4	1	SEE NOTE 3	DRAW TUBE CONNECTOR
5	1	SEE NOTE 4	COLLET

NOTES

- DIMENSIONS SHOWN ARE FOR REFERENCE ONLY.
- THE CHUCK IS SHOWN IN THE NOMINAL CLAMPED POSITION.
- DRAW TUBE CONNECTOR AND THREAD PER CUSTOMER REQUIREMENTS.
- THE CHUCK IS SHOWN WITH THE MAX COLLET BORE.